

# Crosby®

HOOKS & SWIVELS

S-3319



- Designed for utility applications using synthetic rope.
- Suitable for positioning before lifting.
- Hook is forged alloy steel, Quenched & Tempered.
- Design of hook provides needed overhaul weight.
- Utilizes spool & shield designed to protect rope and keep rope positioned correctly on spool.
- Spool provides wider rope bearing surface resulting in an increased area for load distribution and reduces rope abrasion.

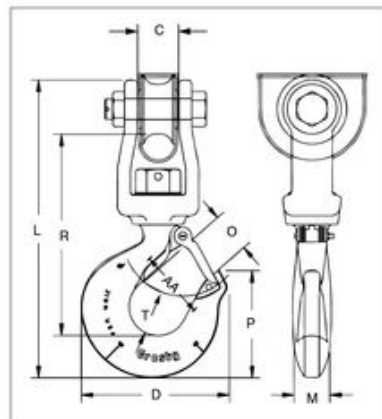

APPLICATION AND WARNING INFORMATION  
SECTION 17

## S-3319 Utility Swivel Hook

Working Load Limit (t)*	Stock No.	Weight Each (lb)	Hook ID Code	Synthetic Rope Size (in)	Dimensions (in)									Replacement Latch Kit Stock No.
					C	D	L	M	O	P	R	T	AA*	
1.63	1002054	4.2	HA	9/16 - 5/8	1.09	3.99	8.75	.94	1.16	2.78	5.94	1.16	2.00	1096468
2.50	1002063	8.0	IA	3/4 - 13/16	1.31	4.84	10.56	1.13	1.41	3.47	7.06	1.53	2.50	1096515
4.50	1002072	15.0	JA	7/8 - 1-1/16	1.78	6.29	12.75	1.44	1.78	4.59	8.69	1.94	3.00	1096562

5:1 Design Factor. Maximum allowable proof load is 2 times the Working Load Limit. \* Deformation indicators.