

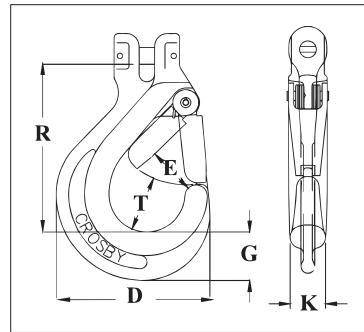

S-314A



- Forged alloy steel - Quenched & Tempered.
- Individually Proof Tested at 2-1/2 times the Working Load Limit with certification.
- Integrated heavy duty latch.
- Meets ASTM A-952 for Grade 80 chain fittings.
- Fatigue rated to 20,000 cycles at 1-1/2 times the Working Load Limit.



S-314A Clevis Chain Hook with Integrated Latch



Chain Size		Stock No.	Grade 8 Alloy Chain Working Load Limit (lb)	Weight Each (lb)	Dimensions (in)						Replacement Latch Stock No.
(in)	(mm)				D	E	G	K	R	T	
-	6	1225020	2500	.69	2.60	.81	.79	.63	2.84	1.02	1291332
1/4 - 5/16	7 - 8	1225021	4500	1.53	3.50	1.08	1.10	.81	3.83	1.28	1291402
3/8	10	1225091	7100	2.84	4.35	1.42	1.16	.94	4.92	1.66	1291472
1/2	13	1225161	12000	5.17	5.45	1.52	1.67	1.16	5.64	1.94	1291542
5/8	16	1225162	18100	9.00	6.56	1.91	2.05	1.50	6.79	2.32	1291612

4:1 Design Factor.