

G-400

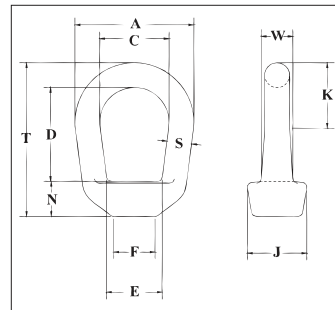

- Forged steel - Quenched & Tempered.
- Hot-dip galvanized
- Tapped with standard UNC class 2 threads after galvanizing.
- Also available in blank (as forged) item (S-4028).
- Meets or exceeds all requirements of ASME B30.26.



G-400 Eye Nuts

Size No.	"S" Stock Size (in)	Stock No	Std. Tap Size (in)	Working Load Limit (lb)	Weight Each (lb)	Dimensions (in)									
						A	C	D	E	F	J	K	N	T	W
1	.25	1090438	1/4	520	.09	1.25	.75	1.00	.75	.50	.69	.63	.38	1.72	.31
2	.31	1090474	3/8	1250	.17	1.62	1.00	1.20	.83	.56	.81	.89	.50	2.09	.41
3A	.38	1090517	1/2	2250	.28	2.00	1.25	1.44	1.08	.81	1.00	1.09	.62	2.55	.50
4	.50	1090535	5/8	3600	.60	2.50	1.50	1.92	1.35	1.00	1.31	1.31	.69	3.25	.69
5	.63	1090553	3/4	5200	1.00	3.00	1.75	2.38	1.59	1.12	1.50	1.57	.88	3.89	.84
6	.75	1090571	7/8	7200	1.65	3.50	2.00	2.63	1.96	1.38	1.88	1.77	.94	4.32	1.00
7	.88	1090599	1	10000	2.69	4.00	2.25	3.06	2.21	1.56	2.13	2.02	1.07	5.01	1.19
8	1.00	1090633	1-1/4	15500	4.38	4.50	2.50	3.50	2.46	1.88	2.38	2.27	1.25	5.78	1.38
9	1.13	1090651	1-3/8	18500	5.00	5.00	2.75	4.00	2.69	2.00	2.56	2.53	1.38	6.51	1.50
10	1.25	1090679	1-1/2	22500	6.78	5.62	3.12	4.31	3.09	2.25	3.00	2.82	1.50	7.06	1.66
11	1.50	1090697	2	40000	14.60	7.12	4.10	6.20	4.09	3.13	3.75	3.68	2.06	9.91	1.94

5:1 Design Factor. Working Load Limit shown is for In-Line pull. Rating based on standard tap size.