

Strong-Bolt® 2 Wedge Anchor — Zinc-Plated Carbon Steel

Code listed for cracked and uncracked concrete, and masonry applications, the Strong-Bolt 2 wedge-type expansion anchor is an optimal choice for high-performance even in seismic and high-wind conditions. Dual undercutting embossments on each clip segment enable secondary expansion should a crack form and intersect the anchor location; this feature significantly increases the ability of Strong-Bolt 2 to carry load if the hole expands.

Features

- Chamfered top designed to prevent mushrooming during installation
- Qualified for static and seismic loading conditions (seismic design categories A through F)
- Suitable for horizontal, vertical and overhead applications
- Qualified for minimum concrete thickness of 3¼", and lightweight concrete-over-steel deck
- Standard (ANSI) fractional sizes: fits standard fixtures and installs with common drill bit and tool sizes
- Tested per ACI355.2 and AC193

Material: Carbon steel

Coating: Zinc plated

Codes: ICC-ES ESR-3037 (concrete); IAPMO UES ER-240 (carbon steel in CMU); City of LA Supplement within ESR-3037 (concrete); City of LA Supplement within ER-240 (carbon steel in CMU); Florida FL15730 (concrete); FL16230 (masonry); UL File Ex3605; FM 3043342 and 3047639; Multiple DOT listings; meets the requirements of Federal Specifications A-A-1923A, Type 4

Installation

 Do not use an impact wrench to set or tighten the Strong-Bolt 2 anchor.

 **Caution:** Oversized holes in the base material will make it difficult to set the anchor and will reduce the anchor's load capacity.

1. Drill a hole in the base material using a carbide drill bit the same diameter as the nominal diameter of the anchor to be installed. Drill the hole to the specified minimum hole depth, and blow it clean using compressed air. (Overhead installations need not be blown clean.) Alternatively, drill the hole deep enough to accommodate embedment depth and dust from drilling.
2. Assemble the anchor with nut and washer so the top of the nut is flush with the top of the anchor. Place the anchor in the fixture, and drive it into the hole until the washer and nut are tight against the fixture.
3. Tighten to the required installation torque.



**Strong-Bolt 2
Wedge Anchor**



Head Stamp

The head is stamped with the length identification letter, bracketed top and bottom by horizontal lines.

Strong-Bolt® 2 Wedge Anchor — Zinc-Plated Carbon Steel

Installation Sequence

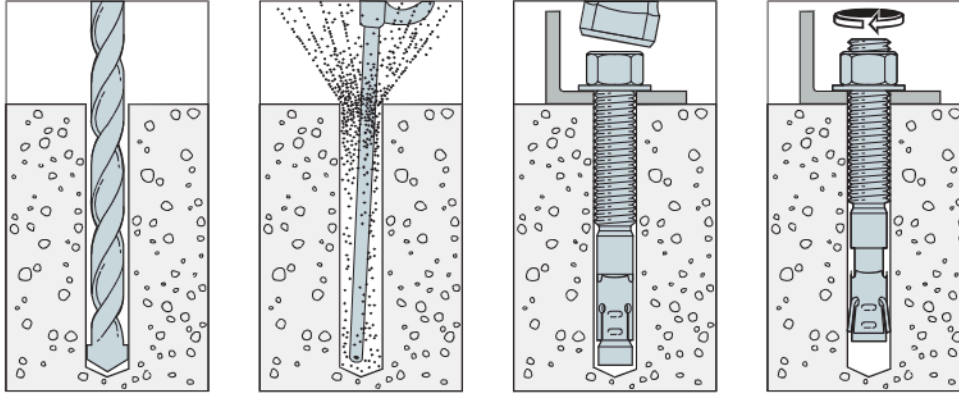

Material Specifications

Anchor Body	Nut	Washer	Clip
Carbon Steel	Carbon Steel, ASTM A 563, Grade A	Carbon Steel ASTM F844	Carbon Steel, ASTM A 568

Strong-Bolt 2 Anchor Installation Data

Strong-Bolt 2 Diameter (in.)	¼	⅜	½	⅝	¾	1
Drill Bit Size (in.)	¼	⅜	½	⅝	¾	1
Min. Fixture Hole (in.)	5/16	7/16	9/16	11/16	7/8	1 1/8
Wrench Size (in.)	7/16	9/16	¾	15/16	1 1/8	1 1/2
Concrete Installation Torque (ft.-lbf) Carbon Steel	4	30	60	90	150	230

Length Identification Head Marks on Strong-Bolt 2 Wedge Anchors (corresponds to length of anchor — inches)

Mark	Units	A	B	C	D	E	F	G	H	I	J	K	L	M	N	O	P	Q	R	S	T	U	V	W	X	Y	Z
From	in.	1 ½	2	2 ½	3	3 ½	4	4 ½	5	5 ½	6	6 ½	7	7 ½	8	8 ½	9	9 ½	10	11	12	13	14	15	16	17	18
Up To But Not Including	in.	2	2 ½	3	3 ½	4	4 ½	5	5 ½	6	6 ½	7	7 ½	8	8 ½	9	9 ½	10	11	12	13	14	15	16	17	18	19

Strong-Bolt® 2 Wedge Anchor — Zinc-Plated Carbon Steel

Strong-Bolt 2 Anchor Product Data — Zinc-Plated Carbon Steel

Size (in.)	Zinc-Plated Carbon Steel Model No.	Drill Bit Diameter (in.)	Thread Length (in.)	Quantity	
				Box	Carton
¼ x 1¾	STB2-25134†	¼	1½ ₁₆	100	500
¼ x 2¼	STB2-25214	¼	17 ₁₆	100	500
¼ x 3¼	STB2-25314	¼	27 ₁₆	100	500
⅜ x 2¼	STB2-37214R50	⅜	1	50	250
⅜ x 2¾	STB2-37234	⅜	1½ ₁₆	50	250
⅜ x 3	STB2-37300	⅜	19 ₁₆	50	250
⅜ x 3½	STB2-37312	⅜	21 ₁₆	50	250
⅜ x 3¾	STB2-37334	⅜	29 ₁₆	50	250
⅜ x 5	STB2-37500	⅜	39 ₁₆	50	200
⅜ x 7	STB2-37700	⅜	59 ₁₆	50	200
½ x 2¾	STB2-50234R25†	½	1¼	25	125
½ x 3¾	STB2-50334	½	21 ₁₆	25	100
½ x 4¼	STB2-50414	½	29 ₁₆	25	100
½ x 4¾	STB2-50434	½	31 ₁₆	25	100
½ x 5½	STB2-50512	½	313 ₁₆	25	100
½ x 7	STB2-50700	½	59 ₁₆	25	100
½ x 8½	STB2-50812	½	6	25	100
½ x 10	STB2-50100	½	6	25	100
½ x 12	STB2-501200R10	½	6	10	20
⅝ x 3½	STB2-62312R20†	⅝	1½	20	80
⅝ x 4½	STB2-62412	⅝	27 ₁₆	20	80
⅝ x 5	STB2-62500	⅝	215 ₁₆	20	80
⅝ x 6	STB2-62600	⅝	315 ₁₆	20	80
⅝ x 7	STB2-62700	⅝	415 ₁₆	20	80
⅝ x 8½	STB2-62812	⅝	415 ₁₆	20	80
⅝ x 10	STB2-62100	⅝	6	20	40
⅝ x 12	STB2-621200R10	⅝	6	10	20
¾ x 4¾	STB2-75434R10†	¾	2½	10	40
¾ x 5½	STB2-75512	¾	33 ₁₆	10	40
¾ x 6¼	STB2-75614	¾	315 ₁₆	10	40
¾ x 7	STB2-75700	¾	411 ₁₆	10	40
¾ x 8½	STB2-75812	¾	6	10	20
¾ x 10	STB2-75100	¾	6	10	20
¾ x 12	STB2-751200R5	¾	6	10	20
1 x 7	STB2-100700	1	3½	5	20
1 x 10	STB2-1001000	1	3½	5	10
1 x 13	STB2-1001300	1	3½	5	10

† Does not meet minimum embedment in code report.

Strong-Bolt® 2 Design Information — Concrete



Zinc-Plated Carbon-Steel Strong-Bolt 2 Installation Information and Additional Data¹

Characteristic	Symbol	Units	Nominal Anchor Diameter, d_a (in.)															
			¼ ⁴	⅜ ⁵		½ ⁵			⅝ ⁵			¾ ⁵		1 ⁵				
Installation Information																		
Nominal Diameter	d_a	in.	¼	⅜		½			⅝			¾		1				
Drill Bit Diameter	d	in.	¼	⅜		½			⅝			¾		1				
Baseplate Clearance Hole Diameter ²	d_c	in.	⅝ ₁₆	7 ₁₆		9 ₁₆			11 ₁₆			7 ₈		11 ₈				
Installation Torque	T_{inst}	ft-lbf	4	30		60			90			150		230				
Nominal Embedment Depth	h_{nom}	in.	1¾	17 ₈	27 ₈	2¼ ⁶	2¾	37 ₈	2¾ ⁶	3¾	51 ₈	3¾ ⁶	41 ₈	5¾	5¼	9¾		
Effective Embedment Depth	h_{ef}	in.	1½	1½	2½	1¾	2¼	3¾	21 ₈	2¾	41 ₂	25 ₈	3¾	5	4½	9		
Minimum Hole Depth	h_{hole}	in.	17 ₈	2	3	2½	3	41 ₈	3	3¾	5¾	3¾	4¾	6	5½	10		
Minimum Overall Anchor Length	ℓ_{anch}	in.	2¼	2¾	3½	2¾	3¾	5½	3½	4½	6	4¾	5½	7	7	13		
Critical Edge Distance	c_{ac}	in.	2½	6½	6	6	6	7½	7½	7½	9	6	6	8	18	13½		
Minimum Edge Distance	c_{min}	in.	1¾	6		6	6	4	4	6½	6½	6½	6½	4¼	4¼	4¼	8	
	for $s \geq$	in.	—	—		6	6	4	4	—	—	5	5	10	10	10	—	
Minimum Spacing	s_{min}	in.	2¼	3		2¾	2¾	2¾	2¾	5	5	2¾	2¾	3½	3½	3½	8	
	for $c \geq$	in.	—	—		12	12	12	12	—	—	8	8	6	6	6	—	
Minimum Concrete Thickness	h_{min}	in.	3¼	3¼	4½	4	4	5½	6	5½	5½	6	77 ₈	6	6	8¾	9	13½
Additional Data																		
Yield Strength	f_{ya}	psi	56,000	92,000		85,000						70,000		60,000				
Tensile Strength	f_{uta}	psi	70,000	115,000						110,000		78,000						
Minimum Tensile and Shear Stress Area	A_{se}	in. ²	0.0318	0.0514		0.105			0.166			0.270		0.472				
Axial Stiffness in Service Load Range — Cracked and Uncracked Concrete	β	lb./in.	73,700 ³	34,820		63,570 ³	63,570		91,370 ³	91,370		118,840 ³	118,840		299,600			

- The information presented in this table is to be used in conjunction with the design criteria of ACI 318-19 Chapter 17, ACI 318-14 Chapter 17 or ACI 318-11 Appendix D.
- The clearance must comply with applicable code requirements for the connected element.
- The tabulated value of β is for installations in uncracked concrete only.
- The ¼"-diameter (6.4 mm) anchor may be installed in top of uncracked normal-weight and sand-lightweight concrete over profile steel deck, where concrete thickness above upper flute meets the minimum thickness specified in this table.
- The ⅜"- through 1"-diameter (9.5 mm through 25.4 mm) anchors may be installed in top of cracked and uncracked normal-weight and sand-lightweight concrete over profile steel deck, where concrete thickness above upper flute meets the minimum thickness specified in this table for ⅜"- through 1"-diameter anchors and in the table on p. 102 for ⅜"- and ½"- diameter anchors.
- Tabulated values for this embedment depth are based on internal testing and they are not listed in ICC-ES ESR-3037.

*See p. 14 for an explanation of the load table icons.

Strong-Bolt® 2 Design Information — Concrete

Zinc-Plated Carbon-Steel Strong-Bolt 2 Tension Strength Design Data¹

Characteristic	Symbol	Units	Nominal Anchor Diameter, d_a (in.)													
			$\frac{1}{4}$ ⁷		$\frac{3}{8}$ ⁸		$\frac{1}{2}$ ⁸		$\frac{5}{8}$ ⁸		$\frac{3}{4}$ ⁸		1 ⁸			
Anchor Category	1, 2 or 3	—	1												2	
Nominal Embedment Depth	h_{nom}	in.	1¼	1⅞	2⅞	2¼ ⁹	2¾	3⅞	2¾ ⁹	3⅞	5⅞	3⅞ ⁹	4⅞	5¼	5¼	9¼
Steel Strength in Tension (ACI 318-19 17.6.1, ACI 318-14 17.4.1 or ACI 318-11 Section D.5.1)																
Steel Strength in Tension	N_{sa}	lb.	2,225	5,600	12,100		19,070		29,700		36,815					
Strength Reduction Factor — Steel Failure ^{2,3}	ϕ_{sa}	—	0.75												0.65	
Concrete Breakout Strength in Tension (ACI 318-19 17.6.2, ACI 318-14 17.4.2 or ACI 318-11 Section D.5.2)																
Effective Embedment Depth	h_{ef}	in.	1½	1½	2½	1¾	2¼	3⅞	2⅞	2¾	4½	2⅞	3⅞	5	4½	9
Critical Edge Distance	c_{ac}	in.	2½	6½	6	6	6	7½	7½	7½	9	6	6	8	18	13½
Effectiveness Factor — Uncracked Concrete	k_{uncr}	—	24					27	24	27	24					
Effectiveness Factor — Cracked Concrete	k_{cr}	—	— ⁶	17	— ¹⁰	17	— ¹⁰	17	— ¹⁰	17	— ¹⁰	17	— ¹⁰	17	— ¹⁰	17
Modification Factor	$\psi_{c,N}$	—	— ⁶	1.00	— ¹⁰	1.00	— ¹⁰	1.00	— ¹⁰	1.00	— ¹⁰	1.00	— ¹⁰	1.00	— ¹⁰	1.00
Strength Reduction Factor — Concrete Breakout Failure ³	ϕ_{cb}	—	0.65												0.55	
Pullout Strength in Tension (ACI 318-19 17.6.3, ACI 318-14 17.4.3.1 or ACI 318-11 Section D.5.3)																
Pullout Strength, Cracked Concrete ($f'_c = 2,500$ psi)	$N_{p,cr}$	lb.	— ⁶	1,300 ⁵	2,775 ⁵	— ¹⁰	N/A ⁴	4,985 ⁵	— ¹⁰	N/A ⁴	6,895 ⁵	— ¹⁰	N/A ⁴	8,500 ⁵	7,700 ⁵	11,185 ⁵
Pullout Strength, Uncracked Concrete ($f'_c = 2,500$ psi)	$N_{p,uncr}$	lb.	N/A ⁴	N/A ⁴	3,340 ⁵	N/A ⁴	3,615 ⁵	5,255 ⁵	N/A ⁴	N/A ⁴	9,025 ⁵	N/A ⁴	7,115 ⁵	8,870 ⁵	8,360 ⁵	9,690 ⁵
Strength Reduction Factor — Pullout Failure ³	ϕ_p	—	0.65												0.55	
Tensile Strength for Seismic Applications (ACI 318-19 17.10.3, ACI 318-14 17.2.3.3 or ACI 318-11 Section D3.3.3)																
Nominal Pullout Strength for Seismic Loads ($f'_c = 2,500$ psi)	$N_{p,eq}$	lb.	— ⁶	1,300 ⁵	2,775 ⁵	— ¹⁰	N/A ⁴	4,985 ⁵	— ¹⁰	N/A ⁴	6,895 ⁵	— ¹⁰	N/A ⁴	8,500 ⁵	7,700 ⁵	11,185 ⁵
Strength Reduction Factor — Pullout Failure ³	ϕ_{eq}	—	0.65												0.55	

- The information presented in this table must be used in conjunction with the design criteria of ACI 318-19 Chapter 17, ACI 318-14 Chapter 17 or ACI 318-11 Appendix D, as applicable, except as modified below.
- The $\frac{1}{4}$ "-, $\frac{3}{8}$ "-, $\frac{1}{2}$ "-, $\frac{5}{8}$ "- and $\frac{3}{4}$ "-diameter carbon steel Strong-Bolt 2 anchors are ductile steel elements as defined in ACI 318-19 2.3, ACI 318-14 2.3 or ACI 318-11 D.1, as applicable. The 1"-diameter carbon steel Strong-Bolt 2 anchor is a brittle steel element as defined in ACI 318-19 2.3, ACI 318-14 2.3 or ACI 318-11 D.1, as applicable.
- The strength reduction factor applies when the load combinations from the IBC or ACI 318 are used and the requirements of ACI 318-19 17.5.3, ACI 318-14 17.3.3 or ACI 318-11 D.4.3, as applicable, are met. If the load combinations of ACI 318-11 Appendix C are used, the appropriate strength reduction factor must be determined in accordance with ACI 318-11 D.4.4.
- N/A (not applicable) denotes that pullout resistance does not need to be considered.
- The characteristic pullout strength for greater concrete compressive strengths shall be increased by multiplying the tabular value by $(f'_c/2,500 \text{ psi})^{0.5}$.
- The $\frac{1}{4}$ "-diameter carbon steel Strong-Bolt 2 anchor installation in cracked concrete is beyond the scope of this table.
- The $\frac{1}{4}$ "-diameter (6.4 mm) anchor may be installed in top of uncracked normal-weight and sand-lightweight concrete over profile steel deck, where concrete thickness above upper flute meets the minimum thickness specified in the table on p. 99.
- The $\frac{3}{8}$ "- through 1"-diameter (9.5 mm through 25.4 mm) anchors may be installed in top of cracked and uncracked normal-weight and sand-lightweight concrete over profile steel deck, where concrete thickness above upper flute meets the minimum thickness specified in the table on p. 99 and in the table on p. 102 for the $\frac{3}{8}$ "- and $\frac{1}{2}$ "-diameter anchors.
- Tabulated values for this embedment depth are based on internal testing and they are not listed in ICC-ES ESR-3037.
- Anchor installation in cracked concrete is beyond the scope of this table for this embedment depth.

⁷See p. 14 for an explanation of the load table icons.

Strong-Bolt® 2 Design Information — Concrete

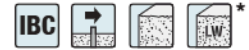

Zinc-Plated Carbon-Steel Strong-Bolt 2 Shear Strength Design Data¹

Characteristic	Symbol	Units	Nominal Anchor Diameter, d_a (in.)													
			$\frac{1}{4}^5$		$\frac{3}{8}^6$		$\frac{1}{2}^6$		$\frac{5}{8}^6$		$\frac{3}{4}^6$		1^6			
Anchor Category	1, 2 or 3	—	1												2	
Nominal Embedment Depth	h_{nom}	in.	1 $\frac{3}{4}$	1 $\frac{7}{8}$	2 $\frac{1}{8}$	2 $\frac{1}{4}$ ⁷	2 $\frac{3}{8}$	3 $\frac{1}{8}$	2 $\frac{3}{4}$ ⁷	3 $\frac{1}{2}$	5 $\frac{1}{8}$	3 $\frac{3}{8}$ ⁷	4 $\frac{1}{8}$	5 $\frac{1}{4}$	5 $\frac{1}{4}$	9 $\frac{3}{4}$
Steel Strength in Shear (ACI 318-19 17.7.1, ACI 318-14 17.5.1 or ACI 318-11 Section D.6.1)																
Steel Strength in Shear	V_{sa}	lb.	965	1,800	5,285	7,235	2,980	11,035	10,220	14,480					15,020	
Strength Reduction Factor — Steel Failure ^{2,3}	ϕ_{sa}	—	0.65												0.60	
Concrete Breakout Strength in Shear (ACI 318-19 17.7.2, ACI 318-14 17.5.2 or ACI 318-11 Section D.6.2)																
Outside Diameter	d_a	in.	0.25	0.375	0.500		0.625		0.750						1.00	
Load-Bearing Length of Anchor in Shear	ℓ_e	in.	1.500	1.500	2.500	1.750	2.250	3.375	2.125	2.750	4.500	2.625	3.375	5.000	4.500	8.000
Strength Reduction Factor — Concrete Breakout Failure ³	ϕ_{cb}	—	0.70													
Concrete Pryout Strength in Shear (ACI 318-19 17.7.3, ACI 318-14 17.5.3 or ACI 318-11 Section D.6.3)																
Coefficient for Pryout Strength	k_{cp}	—	1.0		2.0	1.0	1.0	2.0	1.0	2.0						
Effective Embedment Depth	h_{ef}	in.	1 $\frac{1}{2}$	1 $\frac{1}{2}$	2 $\frac{1}{2}$	1 $\frac{3}{4}$	2 $\frac{1}{4}$	3 $\frac{1}{8}$	2 $\frac{1}{2}$	2 $\frac{3}{4}$	4 $\frac{1}{2}$	2 $\frac{5}{8}$	3 $\frac{3}{8}$	5	4 $\frac{1}{2}$	9
Strength Reduction Factor — Concrete Pryout Failure ³	ϕ_{cp}	—	0.70													
Steel Strength in Shear for Seismic Applications (ACI 318-19 17.10.3, ACI 318-14 17.2.3.3 or ACI 318-11 Section D.3.3.3)																
Shear Strength of Single Anchor for Seismic Loads ($f'_c = 2,500$ psi)	$V_{sa,eq}$	lb.	— ⁴	1,800	— ⁸	6,510	— ⁸	9,930	— ⁸	11,775					15,020	
Strength Reduction Factor — Steel Failure ^{2,3}	ϕ_{eq}	—	0.65												0.60	

- The information presented in this table must be used in conjunction with the design criteria of ACI 318-19 Chapter 17, ACI 318-14 Chapter 17 or ACI 318-11 Appendix D, except as modified below.
- The $\frac{1}{4}$ "-, $\frac{3}{8}$ "-, $\frac{1}{2}$ "-, $\frac{5}{8}$ "- and $\frac{3}{4}$ "-diameter carbon steel Strong-Bolt 2 anchors are ductile steel elements as defined in ACI 318-19 2.3, ACI 318-14 2.3 or ACI 318-11 D.1, as applicable. The 1"-diameter carbon steel Strong-Bolt 2 anchor is a brittle steel element as defined in ACI 318-19 2.3, ACI 318-14 2.3 or ACI 318-11 D.1, as applicable.
- The strength reduction factor applies when the load combinations from the IBC or ACI 318 are used and the requirements of ACI 318-19 17.5.3, ACI 318-14 17.3.3 or ACI 318-11 D.4.3, as applicable, are met. If the load combinations of ACI 318-11 Appendix C are used, the appropriate strength reduction factor must be determined in accordance with ACI 318-11 D.4.4.
- The $\frac{1}{4}$ "-diameter carbon steel Strong-Bolt 2 anchor installation in cracked concrete is beyond the scope of this table.
- The $\frac{1}{4}$ "-diameter (6.4 mm) anchor may be installed in top of uncracked normal-weight and sand-lightweight concrete over profile steel deck, where concrete thickness above upper flute meets the minimum thickness specified in the table on p. 99.
- The $\frac{3}{8}$ "- through 1"-diameter (9.5 mm through 25.4 mm) anchors may be installed in top of cracked and uncracked normal-weight and sand-lightweight concrete over profile steel deck, where concrete thickness above upper flute meets the minimum thickness specified in the table on p. 102.
- Tabulated values for this embedment depth are based on internal testing and they are not listed in ICC-ES ESR-3037.
- Anchor installation in cracked concrete is beyond the scope of this table for this embedment depth.

^{*}See p. 14 for an explanation of the load table icons.

Strong-Bolt® 2 Design Information — Concrete

Zinc-Plated Carbon-Steel Strong-Bolt 2 Information for Installation in the Topside of Concrete-Filled Profile Steel Deck Floor and Roof Assemblies^{1,2,3,4}



Mechanical Anchors

Design Information	Symbol	Units	Nominal Anchor Diameter (in.)		
			3/8	1/2	5/8
Nominal Embedment Depth	h_{nom}	in.	1 7/8	2 3/4	3 3/8
Effective Embedment Depth	h_{ef}	in.	1 1/2	2 1/4	3 3/8
Minimum Concrete Thickness ⁵	$h_{min,deck}$	in.	2 1/2	3 1/4	4 3/16
Critical Edge Distance	$c_{ac,deck,top}$	in.	4 3/4	4	6
Minimum Edge Distance	$c_{min,deck,top}$	in.	4 3/4	4 1/2	12
Minimum Spacing	$s_{min,deck,top}$	in.	7	6 1/2	3 1/2

For SI: 1 inch = 25.4 mm; 1 lbf = 4.45N

1. Installation must comply with the table on p. 99 and Figure 1 below.
2. Design capacity shall be based on calculations according to values in the tables on pp. 100 and 101.
3. Minimum flute depth (distance from top of flute to bottom of flute) is 1 1/2".
4. Steel deck thickness shall be a minimum 20 gauge.
5. Minimum concrete thickness ($h_{min,deck}$) refers to concrete thickness above upper flute.

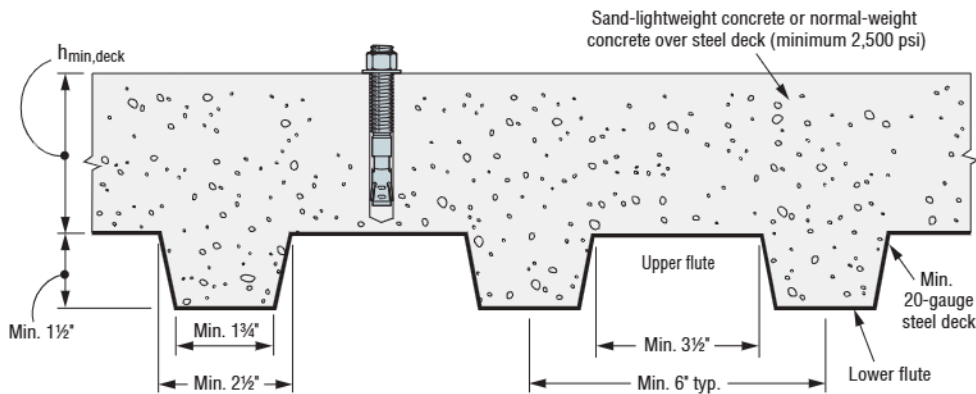

Figure 1

*See p. 14 for an explanation of the load table icons.

Strong-Bolt® 2 Design Information — Concrete

Zinc-Plated Carbon-Steel Strong-Bolt 2 Tension and Shear Strength Design Data for the Soffit of Concrete over Steel Deck Floor and Roof Assemblies^{1,2,6,8,9}



Characteristic	Symbol	Units	Nominal Anchor Diameter (in.)								
			Carbon Steel								
			Lower Flute				Upper Flute				
			%		½		%		½		
Nominal Embedment Depth	h_{nom}	in.	2	3%	2½	4½	3%	5%	4½	2	2½
Effective Embedment Depth	h_{ef}	in.	1½	3	2¼	4	2¾	5	3%	1½	2¼
Installation Torque	T_{inst}	ft.-lbf	30		60		90		150	30	60
Pullout Strength, concrete on steel deck (cracked) ^{3,4}	$N_{p,deck,cr}$	lb.	1,040'	2,615'	2,040'	3,645'	2,615'	4,990'	2,815'	1,340'	3,785'
Pullout Strength, concrete on steel deck (uncracked) ^{3,4}	$N_{p,deck,uncr}$	lb.	1,765'	3,150'	2,580'	3,840'	3,685'	6,565'	3,800'	2,275'	4,795'
Pullout Strength, concrete on steel deck (seismic) ^{3,4}	$N_{p,deck,eq}$	lb.	1,040'	2,615'	2,040'	3,645'	2,615'	4,990'	2,815'	1,340'	3,785'
Steel Strength in Shear, concrete on steel deck ⁵	$V_{sa,deck}$	lb.	1,595	3,490	2,135	4,580	2,640	7,000	4,535	3,545	5,920
Steel Strength in Shear, concrete on steel deck (seismic) ⁵	$V_{sa,deck,eq}$	lb.	1,595	3,490	1,920	4,120	2,375	6,300	3,690	3,545	5,330

- The information presented in this table must be used in conjunction with the design criteria of ACI 318-19 Chapter 19, ACI 318-14 Chapter 17 or ACI 318-11 Appendix D, except as modified below.
- The steel deck profile must comply with the configuration in Figure 2 below, and have a minimum base-steel thickness of 0.035 inch (20 gauge). Steel must comply with ASTM A 653/A 653M SS Grade 33 with minimum yield strength of 33,000 psi. Concrete compressive strength shall be 3,000 psi minimum.
- For anchors installed in the soffit of sand-lightweight or normal-weight concrete over steel deck floor and roof assemblies, calculation of the concrete breakout strength may be omitted.
- In accordance with ACI 318-19 Section 17.6.3.2.1, ACI 318-14 Section 17.4.3.2 or ACI 318-11 Section D.5.3.2, the nominal pullout strength in cracked concrete for anchors installed in the soffit of sand-lightweight or normal-weight concrete over steel deck floor and roof assemblies $N_{p,deck,cr}$ shall be substituted for $N_{p,cr}$. Where analysis indicates no cracking at service loads, the normal pullout strength in uncracked concrete $N_{p,deck,uncr}$ shall be substituted for $N_{p,uncr}$. For seismic loads, $N_{p,deck,eq}$ shall be substituted for N_p .
- In accordance with ACI 318-19 Section 17.7.1.2(c), ACI 318-14 Section 17.5.1.2(c) or ACI 318-11 Section D.6.1.2(c), the shear strength for anchors installed in the soffit of sand-lightweight or normal-weight concrete over steel deck floor and roof assemblies $V_{sa,deck}$ shall be substituted for V_{sa} . For seismic loads, $V_{sa,deck,eq}$ shall be substituted for V_{sa} .
- The minimum anchor spacing along the flute must be the greater of $3.0h_{ef}$ or 1.5 times the flute width.
- The characteristic pull-out strength for greater concrete compressive strengths shall be increased by multiplying the tabular value by $(f'_c / 3,000 \text{ psi})^{0.5}$.
- Concrete shall be normal-weight or structural sand-lightweight concrete having a minimum specified compressive strength, f'_c , of 3,000 psi.
- Minimum distance to edge of panel is $2h_{ef}$.

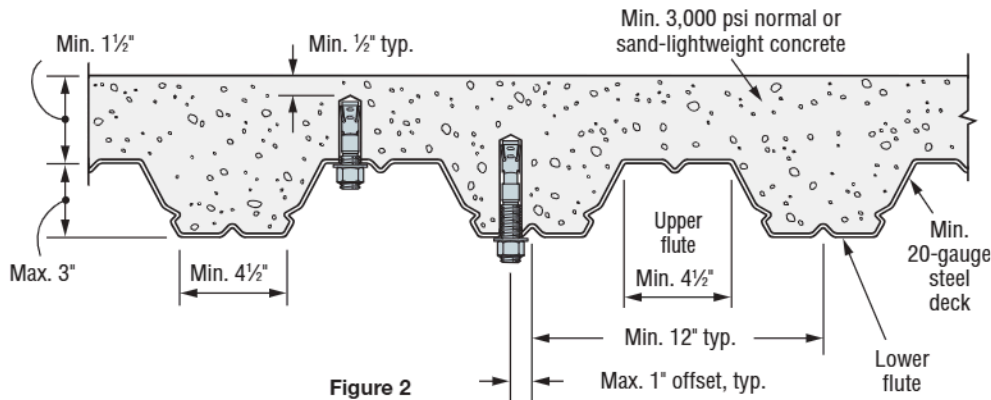

Figure 2

*See p. 14 for an explanation of the load table icons.

Strong-Bolt® 2 Design Information — Concrete

Zinc-Plated Carbon-Steel Strong-Bolt 2 Anchor Tension and Shear Strength Design Data for the Soffit of Concrete over Steel Deck, Floor and Roof Assemblies^{1,2,6,8,9}



Mechanical Anchors

Characteristic	Symbol	Units	Carbon Steel Nominal Anchor Diameter (in.)					
			Installed in Lower Flute					
			3/8	1/2	5/8	3/4	1	1 1/8
Nominal Embedment Depth	h_{nom}	in.	2	3 3/8	2 3/4	4 1/2	3 3/8	5 3/8
Effective Embedment Depth	h_{ef}	in.	1 5/8	3	2 1/4	4	2 3/4	5
Minimum Hole Depth	h_{hole}	in.	2 1/8	3 1/2	3	4 3/4	3 5/8	5 1/8
Minimum Concrete Thickness	$h_{min,deck}$	in.	2	2	2	3 1/4	2	3 1/4
Installation Torque	T_{inst}	ft.-lbf	30		60		90	
Pullout Strength, concrete on steel deck (cracked) ^{3,4,7}	$N_{p,deck,cr}$	lb.	1,295	2,705	2,585	5,850	3,015	5,120
Pullout Strength, concrete on steel deck (uncracked) ^{3,4,7}	$N_{p,deck,uncr}$	lb.	2,195	3,260	3,270	6,165	4,250	6,735
Pullout Strength, concrete on steel deck (seismic) ^{3,4,7}	$N_{p,deck,eq}$	lb.	1,295	2,705	2,585	5,850	3,015	5,120
Steel Strength in Shear, concrete on steel deck ⁵	$V_{sa,deck}$	lb.	1,535	3,420	2,785	5,950	3,395	6,745
Steel Strength in Shear, concrete on steel deck (seismic) ⁵	$V_{sa,deck,eq}$	lb.	1,535	3,420	2,505	5,350	3,055	6,070

- The information presented in this table must be used in conjunction with the design criteria of ACI 318-19 Chapter 17, ACI 318-14 Chapter 17 or ACI 318-11 Appendix D, except as modified below.
- The steel deck profile must comply with the configuration in Figure 3 below, and have a minimum base-steel thickness of 0.035 inch (20 gauge). Steel must comply with ASTM A 653/A 653M SS Grade 50 with minimum yield strength of 50,000 psi. Concrete compressive strength shall be 3,000 psi minimum.
- For anchors installed in the soffit of sand-lightweight or normal-weight concrete over steel deck floor and roof assemblies, calculation of the concrete breakout strength may be omitted.
- In accordance with ACI 318-19 Section 17.6.3.2.1, ACI 318-14 Section 17.4.3.2 or ACI 318-11 Section D.5.3.2, the nominal pullout strength in cracked concrete for anchors installed in the soffit of sand-lightweight or normal-weight concrete over steel deck floor and roof assemblies $N_{p,deck,cr}$ shall be substituted for $N_{p,cr}$. Where analysis indicates no cracking at service loads, the normal pullout strength in uncracked concrete $N_{p,deck,uncr}$ shall be substituted for $N_{p,uncr}$. For seismic loads, $N_{p,deck,eq}$ shall be substituted for N_p .
- In accordance with ACI 318-19 Section 17.7.1.2(c), ACI 318-14 Section 17.5.1.2(c) or ACI 318-11 Section D.6.1.2(c), the shear strength for anchors installed in the soffit of sand-lightweight or normal-weight concrete over steel deck floor and roof assemblies $V_{sa,deck}$ shall be substituted for V_{sa} . For seismic loads, $V_{sa,deck,eq}$ shall be substituted for V_{sa} .
- The minimum anchor spacing along the flute must be the greater of $3.0h_{ef}$ or 1.5 times the flute width.
- The characteristic pull-out strength for greater concrete compressive strengths shall be increased by multiplying the tabular value by $(f'_c / 3,000 \text{ psi})^{1.5}$.
- Concrete shall be normal-weight or structural sand-lightweight concrete having a minimum specified compressive strength, f'_c , of 3,000 psi.
- Minimum distance to edge of panel is $2h_{ef}$.

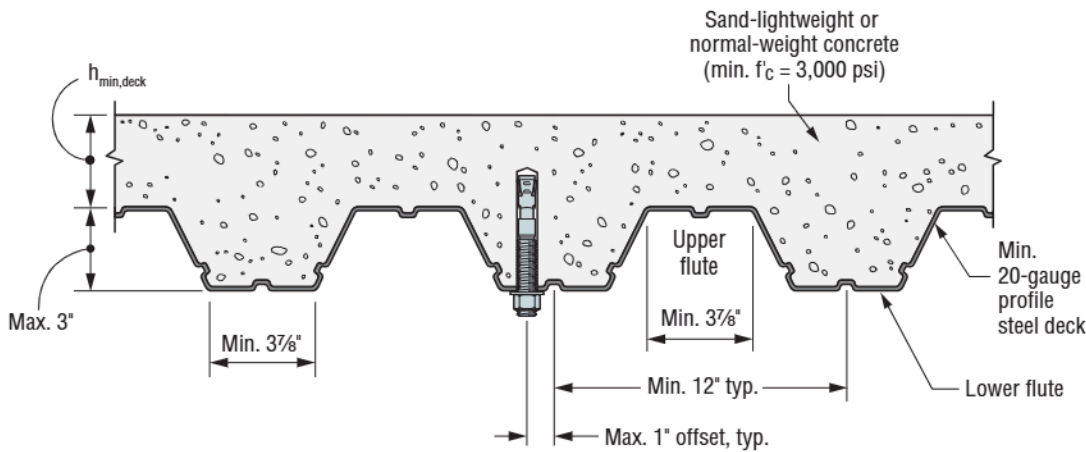
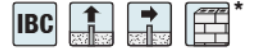

Figure 3

*See p. 14 for an explanation of the load table icons.

Strong-Bolt® 2 Design Information — Masonry

Zinc-Plated Carbon-Steel Strong-Bolt 2 Tension and Shear Loads in 8" Lightweight, Medium-Weight and Normal-Weight Grout-Filled CMU



Size in. (mm)	Drill Bit Diameter (in.)	Min. Embed. Depth in. (mm)	Install. Torque ft.-lb. (N-m)	Critical Edge Dist. in. (mm)	Critical End Dist. in. (mm)	Critical Spacing in. (mm)	Tension Load		Shear Load	
							Ultimate lb. (kN)	Allowable lb. (kN)	Ultimate lb. (kN)	Allowable lb. (kN)
Anchor Installed in the Face of the CMU Wall (See Figure 1)										
¼ (6.4)	¼	1¾ (45)	4 (5.4)	12 (305)	12 (305)	8 (203)	1,150 (5.1)	230 (1.0)	1,500 (6.7)	300 (1.3)
⅜ (9.5)	⅜	2⅝ (67)	20 (27.1)	12 (305)	12 (305)	8 (203)	2,185 (9.7)	435 (1.9)	3,875 (17.2)	775 (3.4)
½ (12.7)	½	3½ (89)	35 (47.5)	12 (305)	12 (305)	8 (203)	2,645 (11.8)	530 (2.4)	5,055 (22.5)	1,010 (4.5)
⅝ (15.9)	⅝	4⅜ (111)	55 (74.6)	20 (508)	20 (508)	8 (203)	4,460 (19.8)	890 (4.0)	8,815 (39.2)	1,765 (7.9)
¾ (19.1)	¾	5¼ (133)	100 (135.6)	20 (508)	20 (508)	8 (203)	5,240 (23.3)	1,050 (4.7)	12,450 (55.4)	2,490 (11.1)

- The tabulated allowable loads are based on a safety factor of 5.0 for installation under the IBC and IRC.
- Listed loads may be applied to installations on the face of the CMU wall at least 1¼" away from head joints.
- Values for 8"-wide concrete masonry units (CMU) with a minimum specified compressive strength of masonry, f'_m , at 28 days is 1,500 psi.
- Embedment depth is measured from the outside face of the concrete masonry unit.
- Tension and shear loads may be combined using the parabolic interaction equation ($n = 5/8$).
- Refer to allowable load adjustment factors for edge distance and spacing on p. 106.

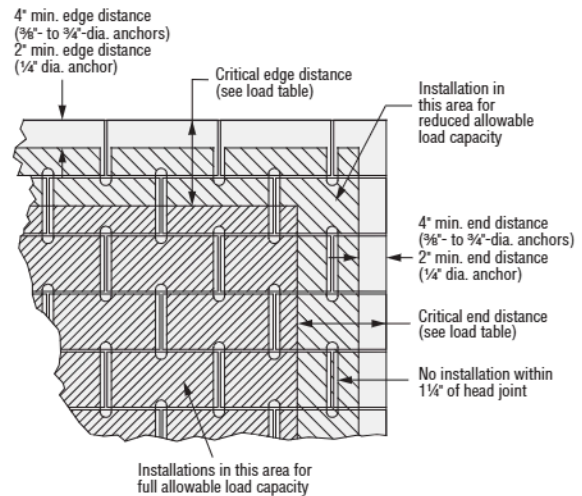

Figure 1

Zinc-Plated Carbon-Steel Strong-Bolt 2 Tension and Shear Loads in 8" Lightweight, Medium-Weight and Normal-Weight Grout-Filled CMU



Size in. (mm)	Drill Bit Diameter in.	Min. Embed. Depth in. (mm)	Install. Torque ft.-lb. (N-m)	Min. Edge Dist. in. (mm)	Critical End Dist. in. (mm)	Critical Spacing in. (mm)	Tension Load		Shear Load Perpendicular to Edge		Shear Load Parallel to Edge	
							Ultimate lb. (kN)	Allowable lb. (kN)	Ultimate lb. (kN)	Allowable lb. (kN)	Ultimate lb. (kN)	Allowable lb. (kN)
Anchor Installed in Cell Opening or Web (Top of Wall) (See Figure 2)												
½ (12.7)	½	3½ (89)	35 (47.5)	1¾ (45)	12 (305)	8 (203)	2,080 (9.3)	415 (1.8)	1,165 (5.2)	235 (1.0)	3,360 (14.9)	670 (3.0)
⅝ (15.9)	⅝	4⅜ (111)	55 (74.6)	1¾ (45)	12 (305)	8 (203)	3,200 (14.2)	640 (2.8)	1,370 (6.1)	275 (1.2)	3,845 (17.1)	770 (3.4)

- The tabulated allowable loads are based on a safety factor of 5.0 for installation under the IBC and IRC.
- Values for 8"-wide concrete masonry units (CMU) with a minimum specified compressive strength of masonry, f'_m , at 28 days is 1,500 psi.
- Tension and shear loads may be combined using the parabolic interaction equation ($n = 5/8$).
- Refer to allowable load adjustment factors for edge distance and spacing on p. 106.

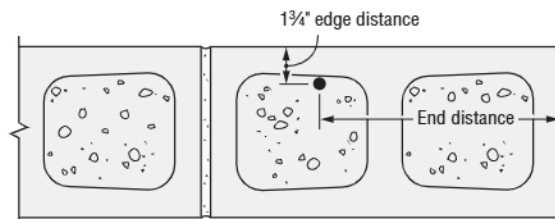

Figure 2

*See p. 14 for an explanation of the load table icons.

Strong-Bolt® 2 Design Information — Masonry

Zinc-Plated Carbon-Steel Strong-Bolt 2 Allowable Load Adjustment Factors for Face-of-Wall Installation in 8" Grout-Filled CMU: Edge Distance and Spacing, Tension and Shear Loads

How to use these charts:

- The following tables are for reduced edge distance and spacing.
- Locate the anchor size to be used for either a tension and/or shear load application.
- Locate the embedment (E) at which the anchor is to be installed.
- Locate the edge distance (c_{act}) or spacing (s_{act}) at which the anchor is to be installed.
- The load adjustment factor (f_c or f_s) is the intersection of the row and column.
- Multiply the allowable load by the applicable load adjustment factor.
- Reduction factors for multiple edges or spacings are multiplied together.

Mechanical Anchors

Edge or End Distance Tension (f_c)

c_{act} (in.)	Dia.	¼	⅜	½	⅝	¾	IBC*
	E	1¼	2⅝	3½	4⅜	5¼	
	c_{cr}	12	12	12	20	20	
	c_{min}	2	4	4	4	4	
	f_{cmin}	1.00	1.00	1.00	1.00	0.97	
2		1.00					
4		1.00	1.00	1.00	1.00	0.97	
6		1.00	1.00	1.00	1.00	0.97	
8		1.00	1.00	1.00	1.00	0.98	
10		1.00	1.00	1.00	1.00	0.98	
12		1.00	1.00	1.00	1.00	0.99	
14					1.00	0.99	
16					1.00	0.99	
18					1.00	1.00	
20					1.00	1.00	

Edge or End Distance Shear (f_s)

c_{act} (in.)	Dia.	¼	⅜	½	⅝	¾	IBC*
	E	1¼	2⅝	3½	4⅜	5¼	
	c_{cr}	12	12	12	20	20	
	c_{min}	2	4	4	4	4	
	f_{cmin}	0.88	0.71	0.60	0.36	0.28	
2		0.88					
4		0.90	0.71	0.60	0.36	0.28	
6		0.93	0.78	0.70	0.44	0.37	
8		0.95	0.86	0.80	0.52	0.46	
10		0.98	0.93	0.90	0.60	0.55	
12		1.00	1.00	1.00	0.68	0.64	
14					0.76	0.73	
16					0.84	0.82	
18					0.92	0.91	
20					1.00	1.00	

Spacing Tension (f_s)

s_{act} (in.)	Dia.	¼	⅜	½	⅝	¾	IBC*
	E	1¼	2⅝	3½	4⅜	5¼	
	s_{cr}	8	8	8	8	8	
	s_{min}	4	4	4	4	4	
	f_{smin}	1.00	1.00	0.93	0.86	0.80	
4		1.00	1.00	0.93	0.86	0.80	
6		1.00	1.00	0.97	0.93	0.90	
8		1.00	1.00	1.00	1.00	1.00	

Spacing Shear (f_s)

s_{act} (in.)	Dia.	¼	⅜	½	⅝	¾	IBC*
	E	1¼	2⅝	3½	4⅜	5¼	
	s_{cr}	8	8	8	8	8	
	s_{min}	4	4	4	4	4	
	f_{smin}	1.00	1.00	1.00	1.00	1.00	
4		1.00	1.00	1.00	1.00	1.00	
6		1.00	1.00	1.00	1.00	1.00	
8		1.00	1.00	1.00	1.00	1.00	

Load Adjustment Factors for Carbon-Steel Strong-Bolt 2 Wedge Anchors in Top-of-Wall Installation in 8" Grout-Filled CMU: Edge Distance and Spacing, Tension and Shear Loads

End Distance Tension (f_c)

s_{act} (in.)	Dia.	½	⅝	IBC*
	E	3½	4⅜	
	c_{cr}	12	12	
	c_{min}	4	4	
	f_{cmin}	1.00	1.00	
4		1.00	1.00	
6		1.00	1.00	
8		1.00	1.00	
10		1.00	1.00	
12		1.00	1.00	

End Distance Shear Perpendicular to Edge (f_c)

c_{act} (in.)	Dia.	½	⅝	IBC*
	E	3½	4⅜	
	c_{cr}	12	12	
	c_{min}	4	4	
	f_{cmin}	0.90	0.83	
4		0.90	0.83	
6		0.93	0.87	
8		0.95	0.92	
10		0.98	0.96	
12		1.00	1.00	

End Distance Shear Parallel to Edge (f_c)

c_{act} (in.)	Dia.	½	⅝	IBC*
	E	3½	4⅜	
	c_{cr}	12	12	
	c_{min}	4	4	
	f_{cmin}	0.53	0.50	
4		0.53	0.50	
6		0.65	0.63	
8		0.77	0.75	
10		0.88	0.88	
12		1.00	1.00	

Spacing Tension (f_s)

s_{act} (in.)	Dia.	½	⅝	IBC*
	E	3½	4⅜	
	s_{cr}	8	8	
	s_{min}	4	4	
	f_{smin}	0.93	0.86	
4		0.93	0.86	
6		0.97	0.93	
8		1.00	1.00	

Spacing Shear Perpendicular or Parallel to Edge (f_s)

s_{act} (in.)	Dia.	½	⅝	IBC*
	E	3½	4⅜	
	s_{cr}	8	8	
	s_{min}	4	4	
	f_{smin}	1.00	1.00	
4		1.00	1.00	
6		1.00	1.00	
8		1.00	1.00	

For footnotes, please see p. 105.

*See p. 14 for an explanation of the load table icons.