

Loadshackle

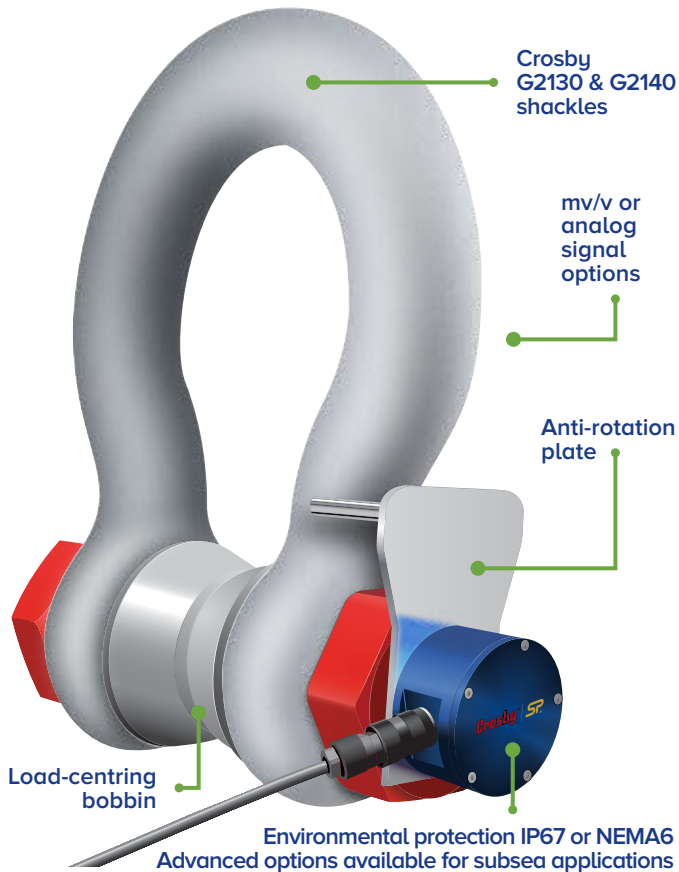

Features and benefits:

- Robust construction
- Compact size and low headroom
- Every Loadshackle proof tested
- Lightweight
- Unrivalled resolution
- Push button tare
- Environmentally sealed to IP67 or NEMA6
- Peak hold
- Advanced options available for subsea applications
- Manufactured using industry leading brand shackles
- mv/v or analog signal options
- Design validated by F.E.A.



Requires connection to Crosby|Straightpoint's Handheld plus (HHP) or External Amplifier range (SA-3420) that can be configured to provide outputs such as 4-20mA, 0-10v, 0-5v for PLC or data logger integration.

Straightpoint's Loadshackle is available from stock in capacities of 3.25t to 400t, as well as being obtainable up to 3000t.

Manufactured from Crosby's industry-leading 2130 Carbon and 2140 Alloy Bolt Type Anchor Shackle, the product offers reduced overall weight and headroom, providing a great fit for low headroom applications.

Utilising the same advanced microprocessor based electronics as all Straightpoint products, the cabled Loadshackle benefits from high sampling rates, extreme resistance to industrial level noise and unprecedented stability.

A huge range of tooling allows Straightpoint to calibrate in shackle for extra accuracy, unlike many other load cell manufacturers. Their cabled Loadshackles are also

environmentally sealed to IP67 or NEMA6 and, as an option, sealed for permanent submersion for sub-sea use.

The cabled Loadshackle range can be used with digital displays, including the Straightpoint Handheld plus, PLCs, data acquisition systems (DAQ), etc.

They are configured with a vast array of output formats to include mV/V, RS-422, RS-485, utilising the ASCII, MODBUS RTU and CAN-BUS protocols or supplied with integral amplifier allowing analogue outputs such as 4-20mA, 0-10v, 0-5v etc.

Whether used in heavy lifting, mooring anchor placement or sub-sea applications, Straightpoint's cabled Loadshackle offers robust construction, advanced electronics, industry leading resolution and accuracy - all at a cost-effective, affordable price.

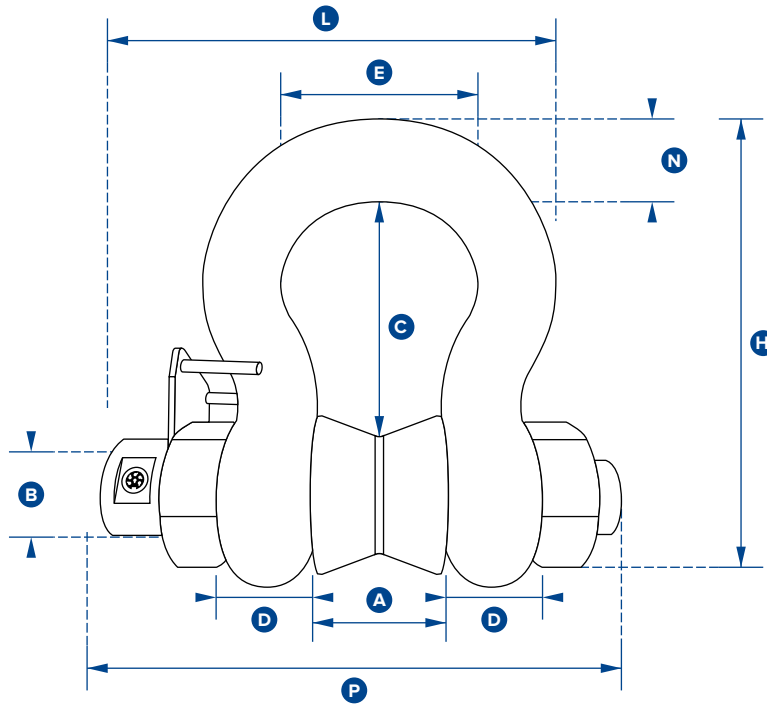

Part Numbers										
SP	SLB3.25T	SLB6.5T	SLB12T	SLB25T	SLB55T	SLB85T	SLB120T	SLB200T	SLB300T	SLB400T
Crosby	2789106	2789111	2789103	2789105	2789110	2789112	2789102	2789104	2789107	2789108
Capacity	3.25te	6.5te	12te	25te	55te	85te	120te	200te	300te	400te
	7150lb	14300lb	26400lb	55000lb	120000lbs	185000lbs	260000lbs	440000lbs	660000lbs	880000lbs
Resolution	0.005te	0.005te	0.01te	0.02te	0.05te	0.05te	0.1te	0.2te	0.5te	0.5te
	10lb	10lb	20lb	50lb	100lb	100lb	200lb	200lb	1000lb	1000lb
Units	tonne									
	lb									
Weight	2.8kg	3.2kg	8kg	18kg	25kg	45kg	85kg	230kg	398kg	556kg
	6.16lb	7lb	17.6lb	40lb	55lb	99lb	187lb	507lb	877lb	1226lb
Safety Factor	5:1 when used with load bobbin									
Operating Temp	-10°C to +50°C or 14°F to 122°F									
Accuracy	±1% of full scale									
Protection	IP67 std [or sub sea as POA option] or NEMA6									
Dimension A	26.9	36.6	51.5	73	82.5	105	127	184	213	210
	1.06"	1.44"	2.03"	2.87"	3.25"	4.13"	5.00"	7.24"	8.39"	8.27"
Dimension ØB	19.1	25.4	35.1	51	57	70	82.5	121	152	178
	0.75"	1.00"	1.38"	2.01"	2.24"	2.76"	3.25"	4.76"	5.98"	7.01"
Dimension C	56.9	79.7	113	170	189.5	253	319.5	366	451	542
	2.24"	3.14"	4.45"	6.69"	7.46"	9.96"	12.58"	14.41"	17.76"	21.34"
Dimension D	14.46	22.4	31.8	44.5	51	66.5	76	116	124	165
	0.57"	0.88"	1.25"	1.75"	2.01"	2.62"	2.99"	4.57"	4.88"	6.50"
Dimension E	42.9	58	82.5	127	164	184	200	279	330	330
	1.69"	2.28"	3.25"	5.00"	6.46"	7.24"	7.87"	10.98"	12.99"	12.99"
Dimension H	103.3	148	210	313	348	453	546	706	871	1022
	4.07"	5.83"	8.27"	12.32"	13.70"	17.83"	21.50"	27.80"	34.29"	40.24"
Dimension L	124.2	153.5	193.8	278	303	365	405	577	649	577
	4.89"	6.04"	7.63"	10.94"	11.93"	14.37"	15.94"	22.72"	25.55"	22.72"
Dimension N	17.5	24.6	35.1	57	61	79	92	127	154	184
	0.69"	0.97"	1.38"	2.24"	2.40"	3.11"	3.62"	5.00"	6.06"	7.24"
Dimension P	140	170	215	290	314	391	438	664	719	781
	5.51"	6.69"	8.46"	11.42"	12.36"	15.39"	17.24"	26.14"	28.31"	30.75"