

MATERIAL BASKETS WITH FIXED SIDES

- Manufactured to exceed all ASME B30.20 and OSHA regulations.
- Painted safety yellow for resistance to corrosion.
- **ALL** material baskets shipped with proof load certification paperwork.
- Durable construction ideally suited to jobsite or warehouse use.
- Pick from lifting points with top rigging.
- Made in U.S.A.
- Custom designs available - call for engineering.

NOT FOR PERSONNEL LIFTING.

Prop 65 – See Page 112

Capacity in Pounds*	Part Number	A	B	Inside Usable	C	D	E	Weight	Includes Shackles
2,500	11827	36	24	33"x33"x22"	4.0	6.0	36	320	1/2"
2,500	11829	48	24	45"x45"x22"	4.0	8.0	48	360	1/2"
2,500	16006	60	24	57"x45"x22"	4.0	8.0	48	450	1/2"

* Call for specifications on larger sizes and capacities

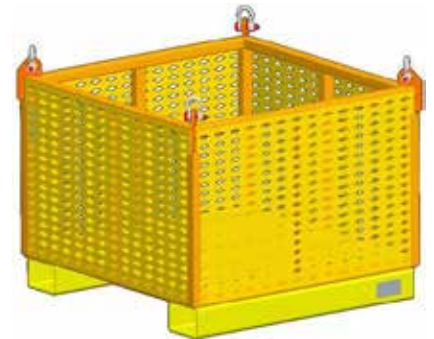
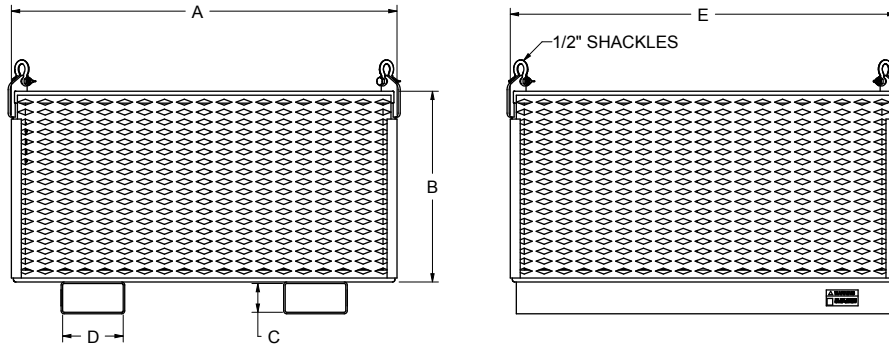

WITH CASTERS

Capacity in Pounds*	Part Number	A	B	Inside Usable	C	D	E	Weight	Includes Shackles
2,500	23954	36	24	33"x33"x22"	4.0	6.0	36	320	1/2"
2,500	23955	48	24	45"x45"x22"	4.0	8.0	48	360	1/2"
2,500	23956	60	24	57"x45"x22"	4.0	8.0	48	450	1/2"



OPTIONAL

Part Number	
24985	4 Leg Top Chain Rigging